

LMUe6000-JM



Easily Realizes Automatic Label Attachment to the Top Surface

This unit is a top-mounted labeling machine that applies the label on the top surface of products in the post-packaging process.

Equipped with convenient functions that are simple to use at the production site, easily realizes high quality and efficiently automatic label attachment.

Productivity Improvement

Changing production methods from the applying labels by hands to automatic labeling machine is contributed to productivity improvement.

Touchscreen

Easy selection with the touchscreen when switching products.



Variety Registration

Settings each type of product can be registered such as label applying position, the amount of delay before applying labels, gap between labels and so on.

LABEL SPECIFICATION

Label Width	15mm - 120mm
Basement Paper Width	18mm - 125mm
Label Length	15mm - 200mm
Label Roll	(O.D.) Maximum ϕ 300mm
Label Paper Core	(I.D.) ϕ 75mm

Outline Dimensional Drawing (LMUe6000NS12-JM)

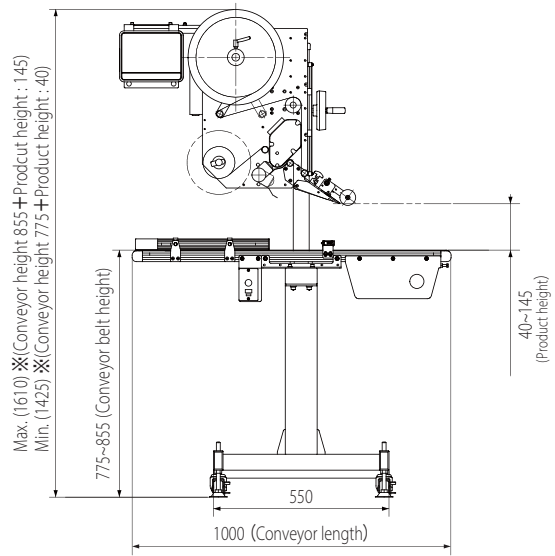
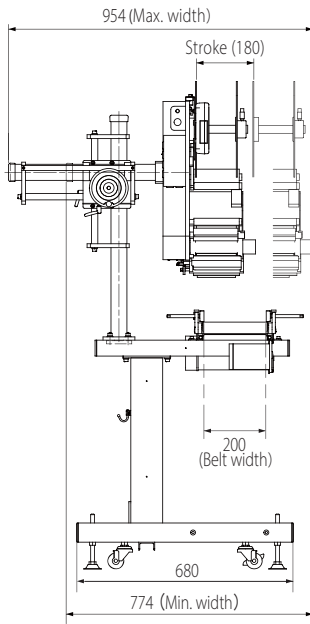

(Unit : mm)

Various Variations

LMUe6000 offers a stand type without a conveyor as well as a conveyor type, which is suitable for incorporation into production lines. Furthermore, we also handle the simultaneous installation of TTO that can be applying by printing the date on the label.

Available In Great Variety Cases !!

- ✓ **Conveyor type** that can be easily used
- ✓ **Stand type** suitable for incorporation into a production
- ✓ **Printer-equipped type** that is printing the date on the label

For more details,
please scan the
QR code



Proposals For Various Labeling Machines That Meet Diverse Needs!!



For Both Sides Labeling



For Wrap-Around Labeling



For Band Form Labeling



For Empty Bags Labeling

The specification may differ from conditions of use. Specification and other information are subject to change without notice.

 **EDM CORPORATION**

5-2,3-Chome Itabashi, Itabashi-ku, Tokyo, Japan

TEL : +81-3-3964-4852 FAX : +81-3-3962-1277

URL : <https://www.edm-net.co.jp/>

Agency